

**DOCUMENT 00 90 00
ADDENDUM**

ADDENDUM NO. [2] Date: March 27, 2018

**RE: WISCONSIN INDIANHEAD TECHNICAL COLLEGE
 WITC – NEW RICHMOND CAMPUS
 ADMINISTRATION AND TRADES AREAS
 RENOVATION AND MAINTENANCE
 HSR PROJECT NO. 17063-3 & 4**

**FROM: HSR Associates, Inc
 100 Milwaukee Street
 La Crosse, WI 54603
 (608) 784-1830**

To: Prospective Bidders

This addendum forms a part of the Contract Documents and modifies the original Bidding Documents dated March 2018. Acknowledge receipt of this Addendum in the space provided on the bid form. Failure to do so may subject the Bidder to disqualification.

This Addendum consists of [1] pages, [1] Specification Section, and [1] 30 x 42 drawing.

CHANGES TO BIDDING REQUIREMENTS AND CONDITIONS OF THE CONTRACT:

1. Section 00 11 15 PREQUALIFIED CONTRACTORS
 - a. Replace Section with new, attached hereto, with additional contractors added.

CHANGES TO DRAWINGS:

2. Sheet A200R1 INTERIOR & CASEWORK ELEVATIONS AND DETAILS 30x42 Sheet attached hereto.
 - a. Revisions clouded on drawing.

END OF DOCUMENT 00 90 00

Page Intentionally Left Blank

SECTION 00 11 15

PREQUALIFIED CONTRACTORS

PART 1: GENERAL

1.01 THE FOLLOWING LIST REPRESENTS APPROVED CONTRACTORS AND SUBCONTRACTORS FOR 2018 PROJECTS:

A. GENERAL CONTRACTORS

1. Angelo Luppino, Inc.
 - a. 11434 N. Island Lake Road, Iron Belt, WI 54536
 - b. Contact: Angelo Luppino
 - c. Phone: 715-561-4906
 - d. Email: aluppinoinc@yahoo.com
2. Arnie Mackey Construction*
 - a. 407 E. Lakeshore Drive, Ashland, WI 54806
 - b. Contact: Scott Sandor Sr.
 - c. Phone: 715-682-9128
 - d. Email: sandorsr@hotmail.com

*Approved for projects \$500,000 or less in scope
3. Derrick Building Solutions
 - a. 1505 Highway 65, New Richmond, WI 54017
 - b. Contact: Mark Johnson
 - c. Phone: 715-246-2320
 - d. Email: mjohnson@derrickbuilt.com
4. Howard Immel, Inc.
 - a. 1820 Radisson Street, Green Bay, WI 54302
 - b. Contact: Laura Reed
 - c. Phone: 920-406-0148
 - d. Email: laurare@immed-builds.com
5. Johnson Wilson Constructors, Inc.
 - a. 4431 West Michigan Street, PO Box 16006, Duluth, MN 55816
 - b. Contact: Shane Johnson
 - c. Phone: 218-628-0202
 - d. Email: sjohnson@johnsonwilson.com
6. Market & Johnson, Inc.
 - a. 2350 Galloway Street, PO Box 630, Eau Claire, WI 54702
 - b. Contact: Dean Griffith
 - c. Phone: 715-834-1213
 - d. Email: dgriffith@market-johnson.com
7. Max Gray Construction
 - a. 2501 5th Avenue West, Hibbing, MN 55746
 - b. Contact: Jim Abrahamson
 - c. Phone: 218-262-6622
 - d. Email: jabrahamson@maxgrayconst.com
8. Miron Construction Co., Inc.
 - a. 500 First Street, Suite 4000, Wausau, WI 54403
 - b. Contact: Tim Andrew
 - c. Phone: 715-841-4000
 - d. Email: tim.andrew@mironconstruction.com

9. Olympic Builders General Contractors
 - a. 405 North Star Road, Holmen, WI 54636
 - b. Contact: William Yahnke
 - c. Phone: 608-526-4622
 - d. Email: office@olympicbuildersgc.com
10. R. J. Jurowski Construction, Inc.
 - a. 36385 Jurowski Drive, PO Box 335, Whitehall, WI 54773
 - b. Contact: Wayne Brown
 - c. Phone: 715-538-4661
 - d. Email: wayneb@rjurowskiconstruction.com
11. Rhom Construction, LLC*
 - a. 2105 N Clairemont Avenue, Eau Claire, WI 54703
 - b. Contact: Nicholas Mohr
 - c. Phone: 715-514-4172
 - d. Email: nmohr@rhomconstruction.com

*Approved for projects \$500,000 or less in scope
12. Thomas Grace Construction
 - a. 5605 Memorial Avenue North, Stillwater, MN 55082
 - b. Contact: Mike Behrens
 - c. Phone: 651-342-1298
 - d. Email: mike.behrens@thomas-grace.com
13. V & S Construction Services, Inc.
 - a. 2019 22 ½ Avenue, PO Box 557, Rice Lake, WI 54868
 - b. Contact: Todd Schieffer
 - c. Phone: 715-234-9174
 - d. Email: todds@vscontractors.com

B. PLUMBING CONTRACTORS

1. A.G. O'Brien Plumbing & Heating Company
 - a. 4907 Lightning Drive, Hermantown, MN 55811
 - b. Contact: Derrill J. Adatte
 - c. Phone: 218-729-9662
 - d. Email: derrill@agobrien.com
2. Badger State, Inc.
 - a. 2507 Fortune Drive, Eau Claire, WI 54703
 - b. Contact: Fred Gardner
 - c. Phone: 715-874-7777
 - d. Email: fred@badgerstateinc.com
3. Bartingale Mechanical, Inc.
 - a. 43213 Louis Avenue, Suite G, Eau Claire, WI 54703
 - b. Contact: Chuck Falch
 - c. Phone: 715-835-3169
 - d. Email: chuckfalch@bartingalemechanical.com
4. Belknap Plumbing & Heating, Inc.
 - a. 1414 Belknap Street, Superior, WI 54880
 - b. Contact: Chris Scharte
 - c. Phone: 715-394-7754
 - d. Email: cscharte@belknapsd.com

5. Blakeman Plumbing & Heating, Inc.
 - a. 44941 State Hwy 13, Ashland, WI 54806
 - b. Contact: Dean Blakeman
 - c. Phone: 715-682-6050
 - d. Email: dean@blakemanplumbing.com
6. Certified, Inc.
 - a. 350 Sunday Drive, Altoona, WI 54720
 - b. Contact: Russ Ryan
 - c. Phone: 715-834-5409
 - d. Email: russr@certified-plumbing-heating.com
7. Countryside Plumbing & Heating, Inc.
 - a. 321 Wisconsin Drive, New Richmond, WI 54017
 - b. Contact: David Wilcox
 - c. Phone: 715-246-2660
 - d. Email: dave@countrysideph.com
8. Halverson Brothers, Inc. Plumbing & Heating
 - a. 1020 North Broadway, Menomonie, WI 54751
 - b. Contact: Mark Dahms
 - c. Phone: 715-235-0651
 - d. Email: halbros@wwt.net
9. J.F. Ahern
 - a. 5315 Freitag Drive, Menomonie, WI 54751
 - b. Contact: Dave Leisses
 - c. Phone: 715-233-1841
 - d. Email: dleisses@jfahern.com
10. KBK Services
 - a. 1207 Lakeshore Drive East, PO Box 546, Ashland, WI 54806
 - b. Contact: Chris Kontny
 - c. Phone: 715-682-3002
 - d. Email: ckontny@kbkservices.com
11. Rogers Plumbing, Inc.
 - a. E4457 Hwy 12, Menomonie, WI 54751
 - b. Contact: Kevin Lannon
 - c. Phone: 715-235-1132
 - d. Email: themail@rogersplumbing.com
12. The Jamar Company
 - a. 4701 Mike Colalillo Drive, Duluth, MN 55807
 - b. Contact: Scott Torvinen
 - c. Phone: 218-628-1027
 - d. Email: scott.torvinen@jamarcompany.us

C. MECHANICAL CONTRACTORS

1. A.G. O'Brien Plumbing & Heating Company
 - a. 4907 Lightning Drive, Hermantown, MN 55811
 - b. Contact: Derrill J. Adatte
 - c. Phone: 218-729-9662
 - e. Email: derrill@agobrien.com

2. Badger State, Inc.
 - a. 2507 Fortune Drive, Eau Claire, WI 54703
 - b. Contact: Fred Gardner
 - c. Phone: 715-874-7777
 - d. Email: fred@badgerstateinc.com
3. Bartingale Mechanical, Inc.
 - a. 43213 Louis Avenue, Suite G, Eau Claire, WI 54703
 - b. Contact: Chuck Falch
 - c. Phone: 715-835-3169
 - d. Email: chuckfalch@bartingalemechanical.com
4. Belknap Plumbing & Heating, Inc.
 - a. 1414 Belknap Street, Superior, WI 54880
 - b. Contact: Chris Scharte
 - c. Phone: 715-394-7754
 - d. Email: cscharte@belknapsd.com
5. Blakeman Plumbing & Heating, Inc.
 - a. 44941 State Hwy 13, Ashland, WI 54806
 - b. Contact: Dean Blakeman
 - c. Phone: 715-682-6050
 - d. Email: dean@blakemanplumbing.com
6. Certified, Inc.
 - a. 350 Sunday Drive, Altoona, WI 54720
 - b. Contact: Russ Ryan
 - c. Phone: 715-834-5409
 - d. Email: russr@certified-plumbing-heating.com
7. Countryside Plumbing & Heating, Inc.
 - a. 321 Wisconsin Drive, New Richmond, WI 54017
 - b. Contact: David Wilcox
 - c. Phone: 715-246-2660
 - d. Email: dave@countrysideph.com
8. Halverson Brothers, Inc. Plumbing & Heating
 - a. 1020 North Broadway, Menomonie, WI 54751
 - b. Contact: Mark Dahms
 - c. Phone: 715-235-0651
 - d. Email: halbros@wwt.net
9. J.F. Ahern
 - a. 5315 Freitag Drive, Menomonie, WI 54751
 - b. Contact: Dave Leisses
 - c. Phone: 715-233-1841
 - d. Email: dleisses@jfahern.com
10. KBK Services
 - a. 1207 Lakeshore Drive East, PO Box 546, Ashland, WI 54806
 - b. Contact: Chris Kontny
 - c. Phone: 715-682-3002
 - d. Email: ckontny@kbkservices.com
11. Paul's Sheet Metal, Inc.
 - a. 1017 Haugen Avenue, PO Box 247, Rice Lake, WI 54868
 - b. Contact: Michael Paul
 - c. Phone: 715-234-7707
 - d. mike@paulssheetmetal.com

12. Sheet Metal Enterprises
 - a. 601 Knapp Street, Chetek, WI 54728
 - b. Contact: Ryan Hoefler
 - c. Phone: 715-924-4499
 - d. Email: ryan@smewi.com
13. The Jamar Company
 - a. 4701 Mike Colalillo Drive, Duluth, MN 55807
 - b. Contact: Scott Torvinen
 - c. Phone: 218-628-1027
 - d. Email: scott.torvinen@jamarcompany.us

D. ELECTRICAL CONTRACTORS

1. B & B Electric, Inc.
 - a. 1303 Western Avenue, Eau Claire, WI 54703
 - b. Contact: Michael Bergh
 - c. Phone: 715-832-1676
 - d. mb@b-belectricinc.com
2. Belknap Electric, Inc.
 - a. 1513 Belknap Street, Superior, WI 54880
 - b. Contact: Chris Krook
 - c. Phone: 715-394-7769
 - d. Email: chriskrook@belknapelectric.com
3. Benson Electric Company
 - a. 1102 North Third Street, Superior, WI 54880
 - b. Contact: Nathan Sapik
 - c. Phone: 715-394-5547
 - d. Email: nate@becotm.com
4. Meyers Electric Service, LLC
 - a. 900 Lindy Street, Rice Lake, WI 54868
 - b. Contact: Dale Meyers
 - c. Phone: 715-234-3901
 - d. Email: dale@meyerelectricllc.com
5. Neo Electrical Solutions, LLC
 - a. 2365 Willis Miller Drive, Hudson, WI 54016
 - b. Contact: Kyle Pheneger
 - c. Phone: 715-808-0463
 - d. Email: kylep@neoelectrical.com
6. NEI Electric
 - a. 605 Industrial Parkway, St. Croix Falls, WI 54024
 - b. Contact: John Gerlach
 - c. Phone: 715-481-3854
 - d. Email: jgerlach@neielectric.com
7. Simon Electric Construction Company, Inc.
 - a. 345 St. Croix Avenue, New Richmond, WI 54017
 - b. Contact: Judy Simon
 - c. Phone: 715-246-3873
 - d. Email: judy@simon-electric.com

8. TJ Electric, Inc.
 - a. 1049 Starr Avenue, Eau Claire, WI 54703
 - b. Contact: Jordan Burch
 - c. Phone: 715-834-0400
 - d. Email: jordan@tjelectricinc.com
9. Van Ert Electric Company, Inc.
 - a. 7019 Stewart Avenue, Wausau, WI 54401
 - b. Contact: Tim Jones
 - c. Phone: 715-845-4308
 - d. Email: tjones@vanert.com

E. LOW VOLTAGE CONTRACTORS

1. B & B Electric, Inc.
 - a. 1303 Western Avenue, Eau Claire, WI 54703
 - b. Contact: Michael Bergh
 - c. Phone: 715-832-1676
 - d. Email: mb@b-belectricinc.com
2. Belknap Electric, Inc.
 - a. 1513 Belknap Street, Superior, WI 54880
 - b. Contact: Chris Krook
 - c. Phone: 715-394-7769
 - d. Email: chriskrook@belknapelectric.com
3. Benson Electric Company
 - a. 1102 North Third Street, Superior, WI 54880
 - b. Contact: Nathan Sapik
 - c. Phone: 715-394-5547
 - d. Email: nate@becotm.com
4. Eau Claire Communications
 - a. 1060 Western Avenue, Suite 3, Eau Claire, WI 54703
 - b. Contact: John Kirscht
 - c. Phone: 715-835-3722
 - d. Email: johnk@eauclairecommunications.com
5. NEI Electric
 - a. 605 Industrial Parkway, St. Croix Falls, WI 54024
 - b. Contact: John Gerlach
 - c. Phone: 715-481-3854
 - d. Email: jgerlach@neielectric.com
6. Neo Electrical Solutions, LLC
 - a. 2365 Willis Miller Drive, Hudson, WI 54016
 - b. Contact: Kyle Pheneger
 - c. Phone: 715-808-0463
 - d. Email: kylep@neoelectrical.com
7. Simon Electric Construction Company, Inc.
 - a. 345 St. Croix Avenue, New Richmond, WI 54017
 - b. Contact: Judy Simon
 - c. Phone: 715-246-3873
 - d. Email: judy@simon-electric.com

8. Van Ert Electric Company, Inc.
 - a. 7019 Stewart Avenue, Wausau, WI 54401
 - b. Contact: Tim Jones
 - c. Phone: 715-845-4308
 - d. tjones@vanert.com

F. ROOFING CONTRACTORS

1. Arnie Mackey Construction*
 - a. 407 E. Lakeshore Drive, Ashland, WI 54806
 - b. Contact: Scott Sandor Sr.
 - c. Phone: 715-682-9128
 - d. Email: sandorsr@hotmail.com

*Approved for projects \$500,000 or less in scope
2. Lake Area Roofing and Construction, Inc.
 - e. 2141 107th Ln NE, Minneapolis, MN 55449
 - f. Contact: Gene Hollister
 - g. Phone: 763-786-5187
 - h. Email: genehollister@lakearearroofing.com
3. Nieman Central Wisconsin Roofing Co.
 - a. N2599 24th Avenue, Lyndon Station, WI 53944
 - b. Contact: Larry Hadac
 - c. Phone: 608-666-3342
 - d. Email: larry@niemancwroofing.com
4. Paul's Sheet Metal, Inc.
 - a. 1017 Haugen Avenue, PO Box 247, Rice Lake, WI 54868
 - b. Contact: Michael Paul
 - c. Phone: 715-234-7707
 - d. mike@paulssheetmetal.com
5. The Jamar Company
 - a. 4701 Mike Colalillo Drive, Duluth, MN 55807
 - b. Contact: Scott Torvinen
 - c. Phone: 218-628-1027
 - d. Email: scott.torvinen@jamarcompany.us

PART 2: PRODUCTS – NOT USED.

PART 3: EXECUTION – NOT USED.

END OF SECTION 00 11 15

Page Intentionally Left Blank

No.	Description	Date
A1	ADDENDUM #1	03/23/2018
A2	ADDENDUM #2	03/27/2018

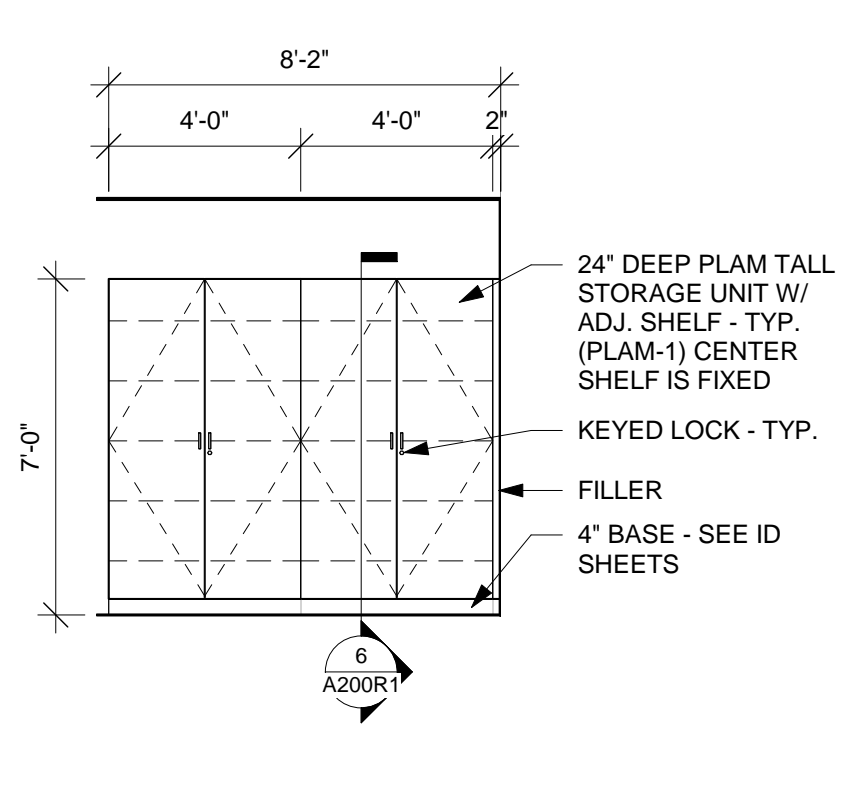

1 CASEWORK ELEV
1/4" = 1'-0"

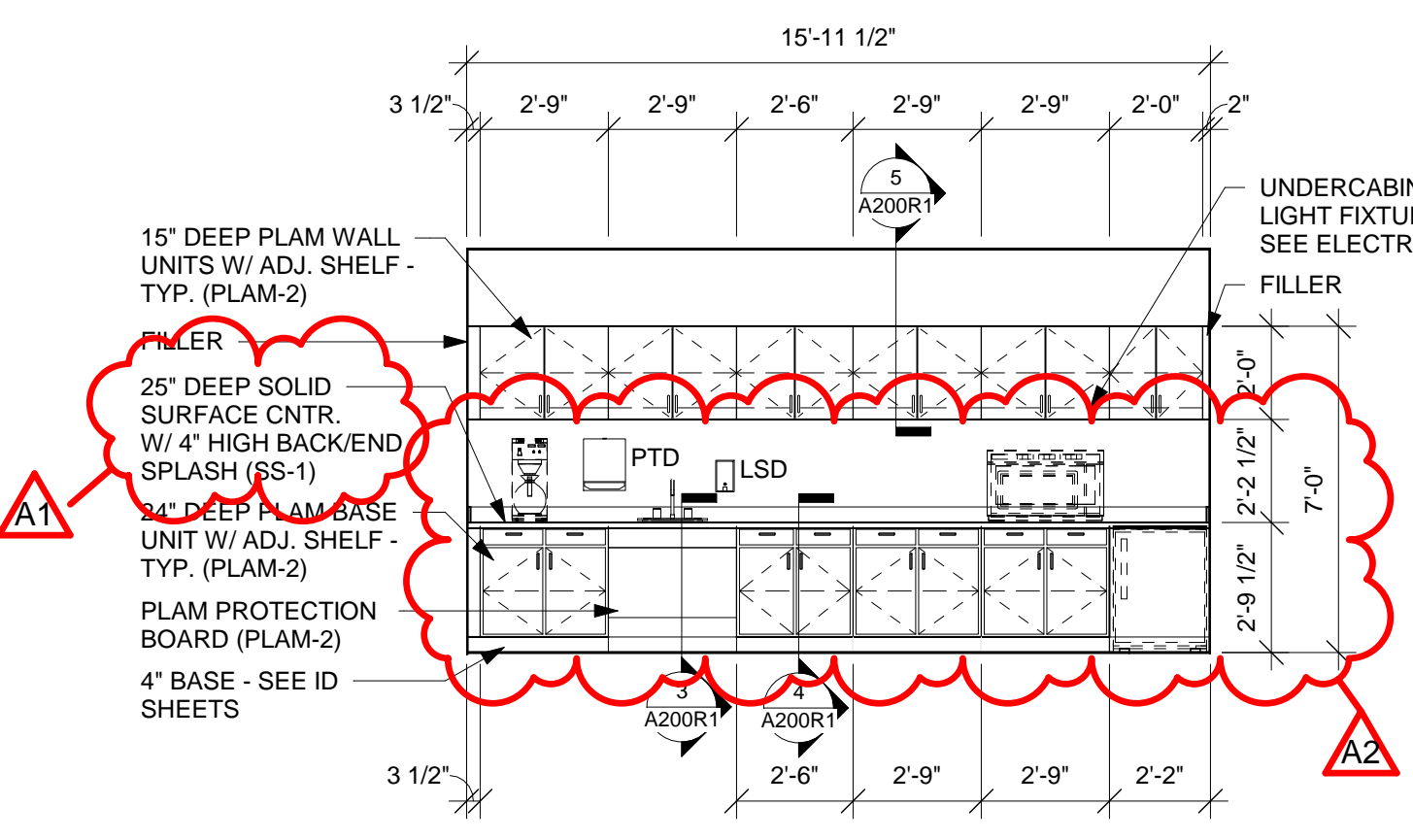

2 CASEWORK ELEV
1/4" = 1'-0"

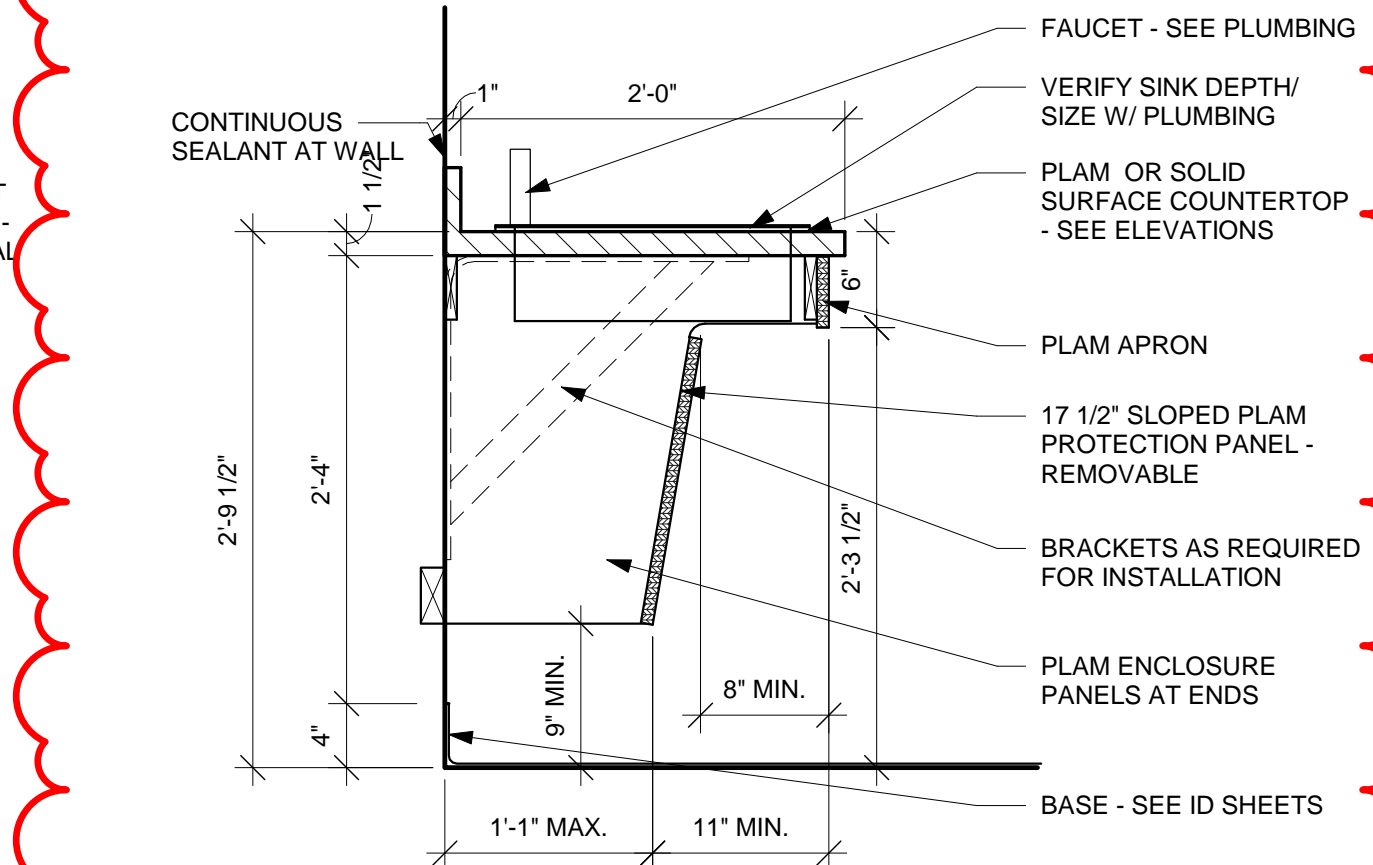

3 CSWK SECTION
1" = 1'-0"

CASEWORK GENERAL NOTES:
A ALL EXPOSED ENDS OF CASEWORK SHALL HAVE LAMINATE FINISH.
B CASEWORK/PANEL MANUF. TO ENSURE ALL PANELS ARE BALANCED - FINISHED BOTH SIDES.

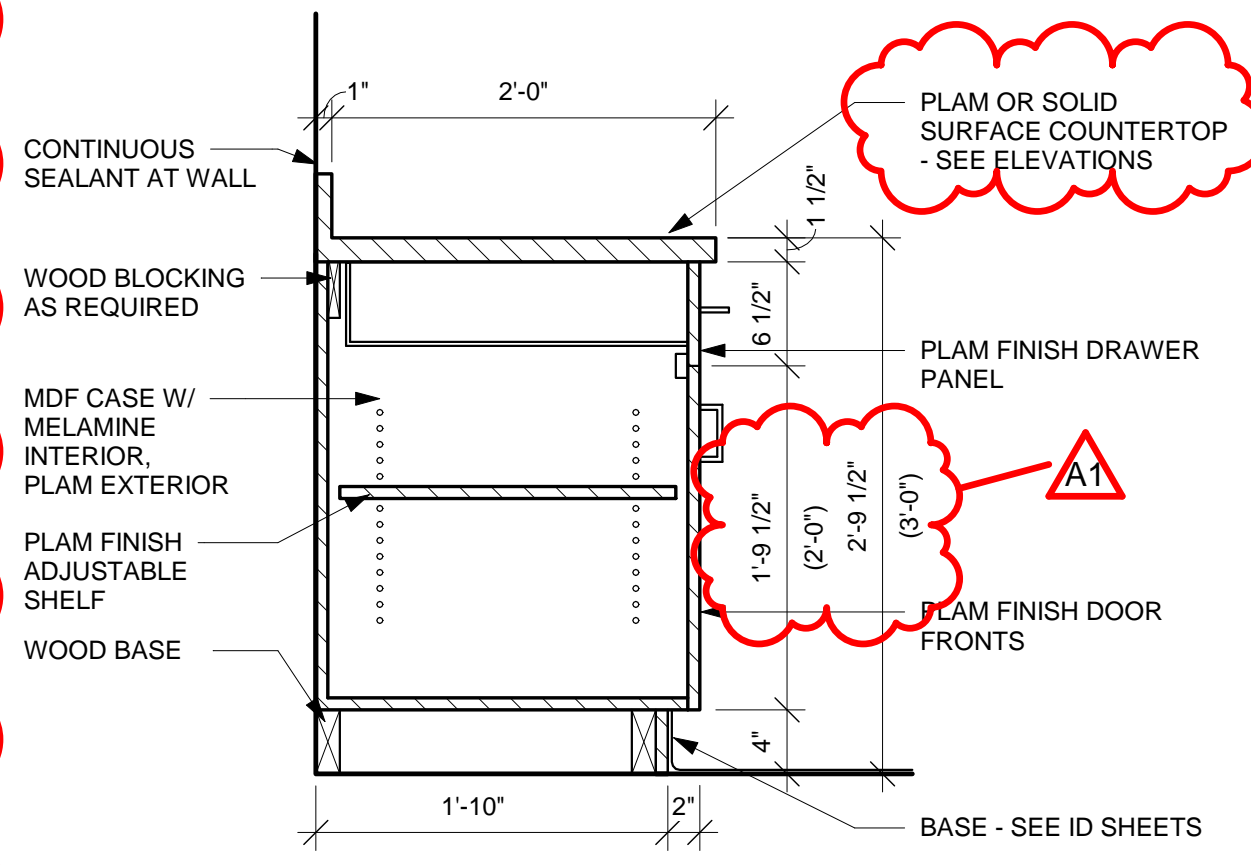

4 CSWK SECTION
1" = 1'-0"

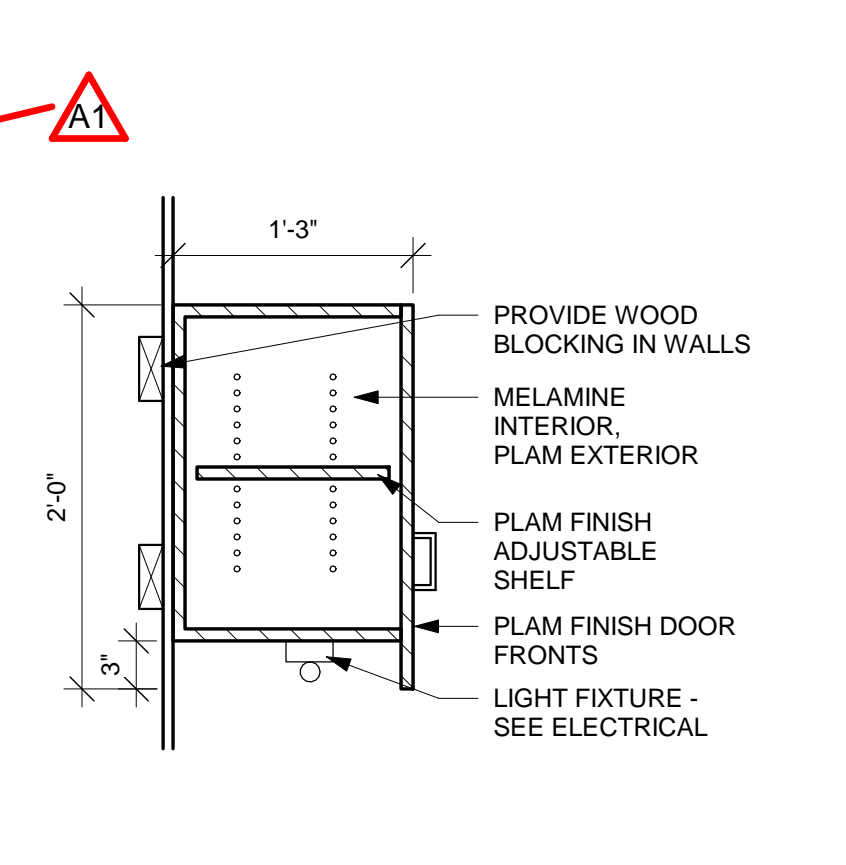

5 CSWK SECTION
1" = 1'-0"

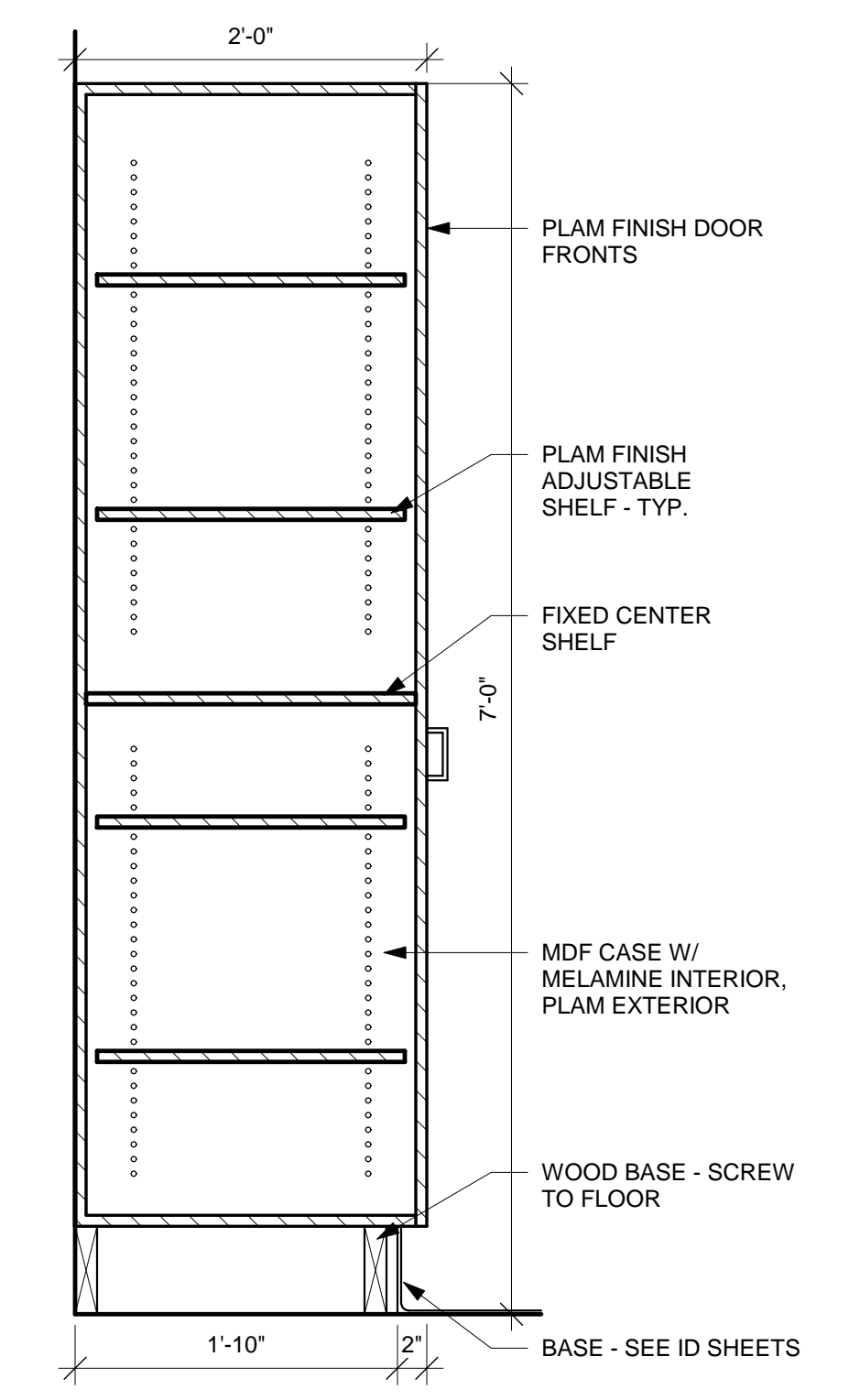

6 CSWK - TALL CAB
1" = 1'-0"

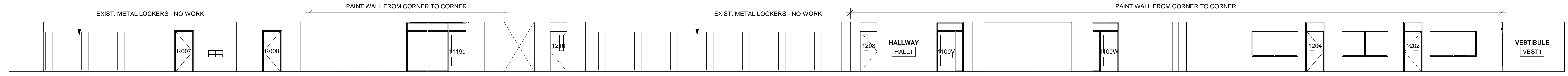

7 INTERIOR ELEVATION
1/8" = 1'-0"

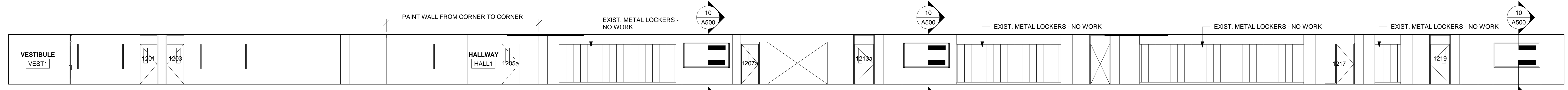

8 INTERIOR ELEVATION
1/8" = 1'-0"

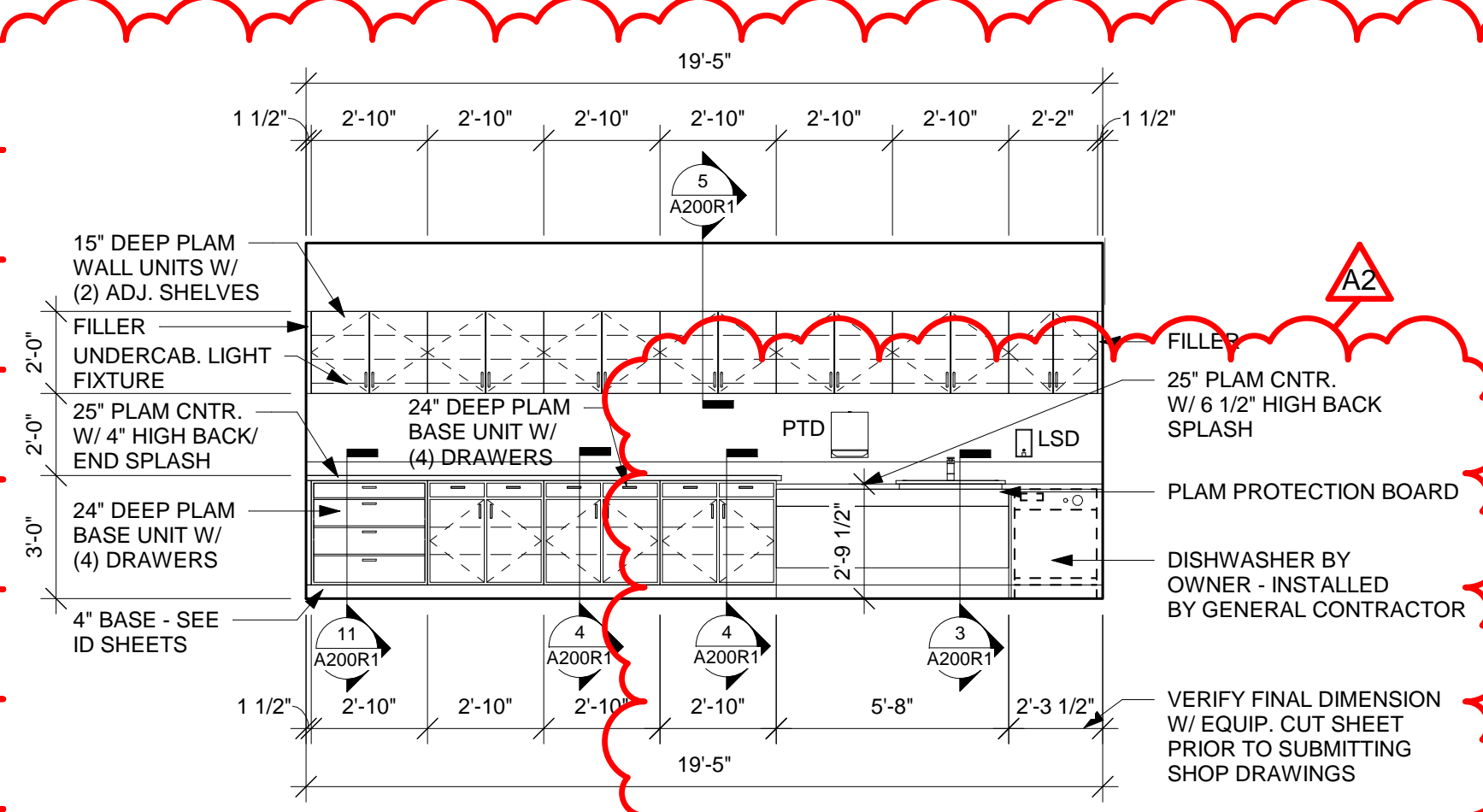

9 CASEWORK ELEV
1/4" = 1'-0"

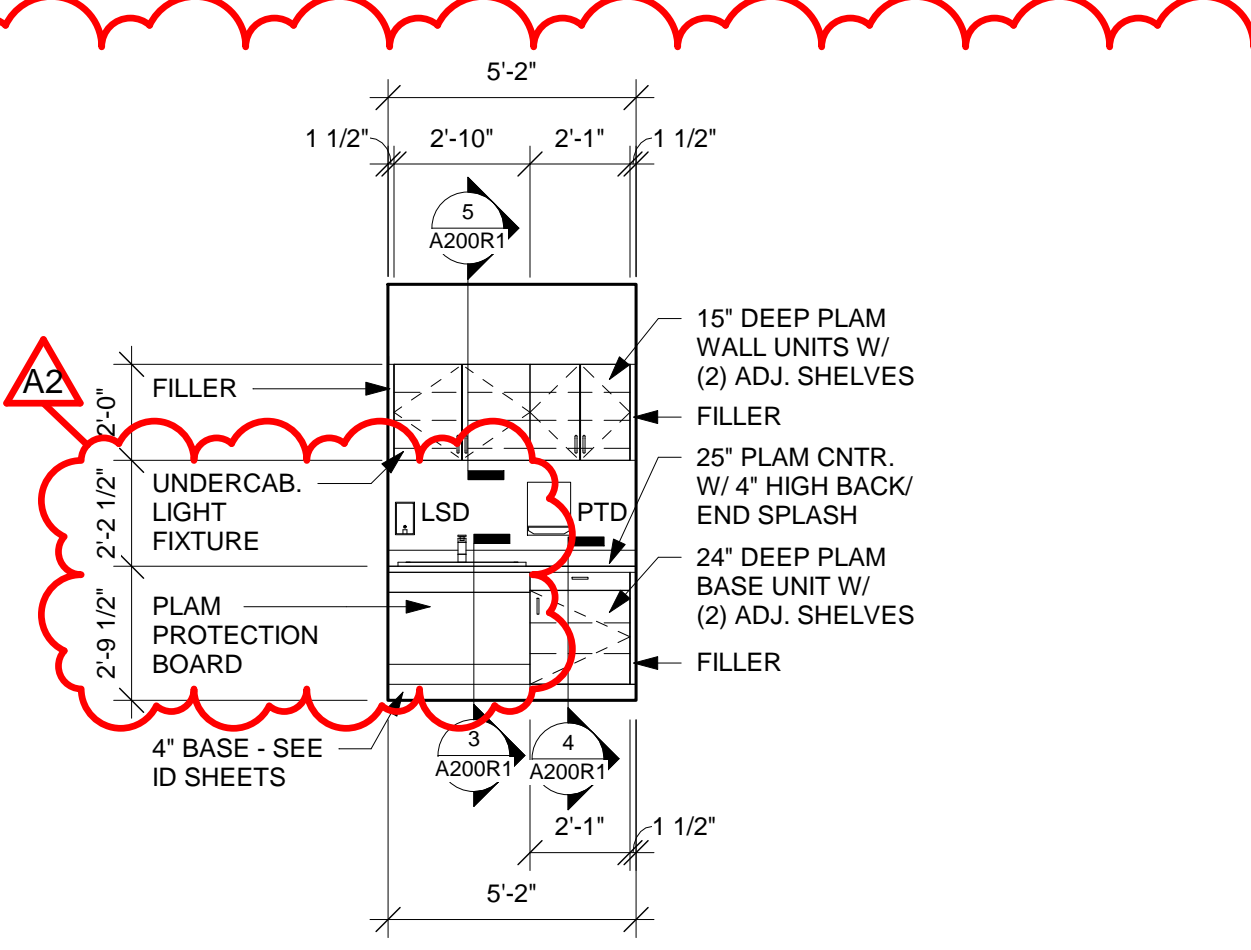

10 CASEWORK ELEV
1/4" = 1'-0"

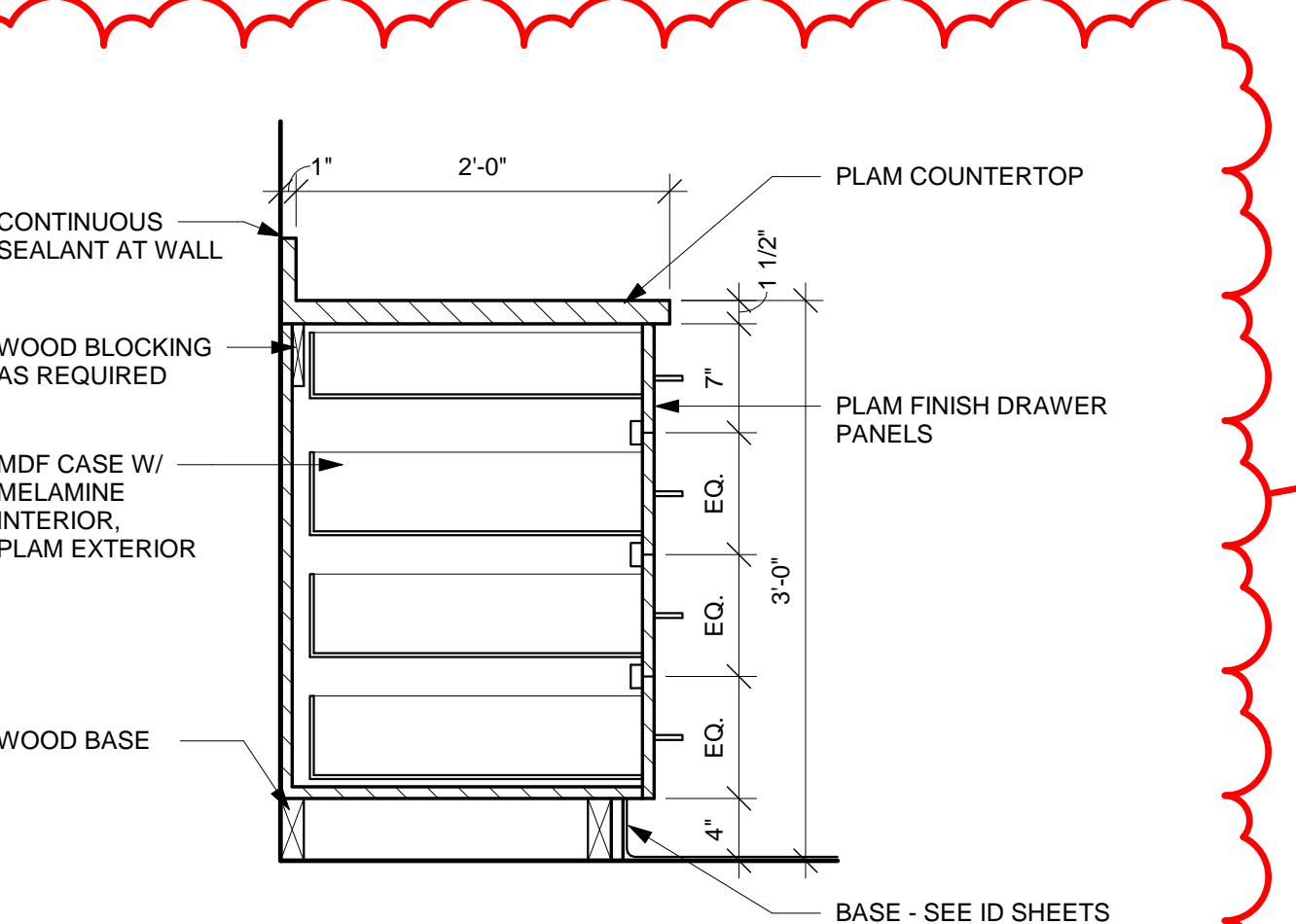

11 CSWK SECTION
1" = 1'-0"